

GTR-100

GENERATOR CONTROL MODULE



Introduction

GTR100 is a compact, reasonable pricing range external manual start controller module, ; protect and warning alert function. Graphical LCD interface clearly displays the system; capable of monitoring speeding, high temperature, low oil pressure, over crank, emergency brake, Low frequency, low battery and Aux. Input 1 . The controller has frequency, battery voltage, operating timing display and RPM value built-in, lowering packaging cost. It's a high performance, low cost remote control module.

The controller uses traditional relay output, which allows higher voltage output. The parameters can be configured directly through the Dip switch, suiting all different kinds of system requirement, gives more flexibility to the end-user. It also uses EURO type quick install/uninstall terminal connector, offers you with great convenience.

Features

- External Manual start
- Generator monitor and protection
- Back-lit graphical LCD display
- Parameter setting by back panel Dip Switch
- Data display: frequency, battery voltage, operating time
- Input configurable in NO/NC mode
- Three configurable auxiliary outputs
- Wide acceptable working voltage 8~36V
- Pluggable Euro type terminal block wiring for quick (un)installation
- Low power consumption 100 mA@12V; 50 mA@24V

Protecting functions

- Emergency stop: delay 0.2 sec/action: stop
- Low battery voltage: delay 5 sec/action: warning
- Speeding: delay 2 sec/action: stop
- High water temp: delay 2 sec/action: stop
- Low oil pressure: delay 2 sec/action: stop
- Cranking time: 10 sec.
- Crank disconnect: 0.5 sec./16 Hz
- Low frequency: 6 sec.

Specification

- **DC Supply**
8~36 V (DC)
- **Power consumption**
Max. 5 W, 100 mA@12 V; 50 mA@ 24V
- **Measuring Frequency**
Min AC volt: 5V
Range : 0~80 Hz
- **Measuring DC voltage**
Range : 10~31 V
- **Relay output**
5 A/30 V
- **Ambient Temperature Range**
-30°C~70°C
- **Dimension (W*H*D)**
72 mm x 72 mm x 58 mm
- **Panel cut-out (W*H)**
68 mm x 68 mm
- **Weight**
175 g(0.38 lb)

Dimension

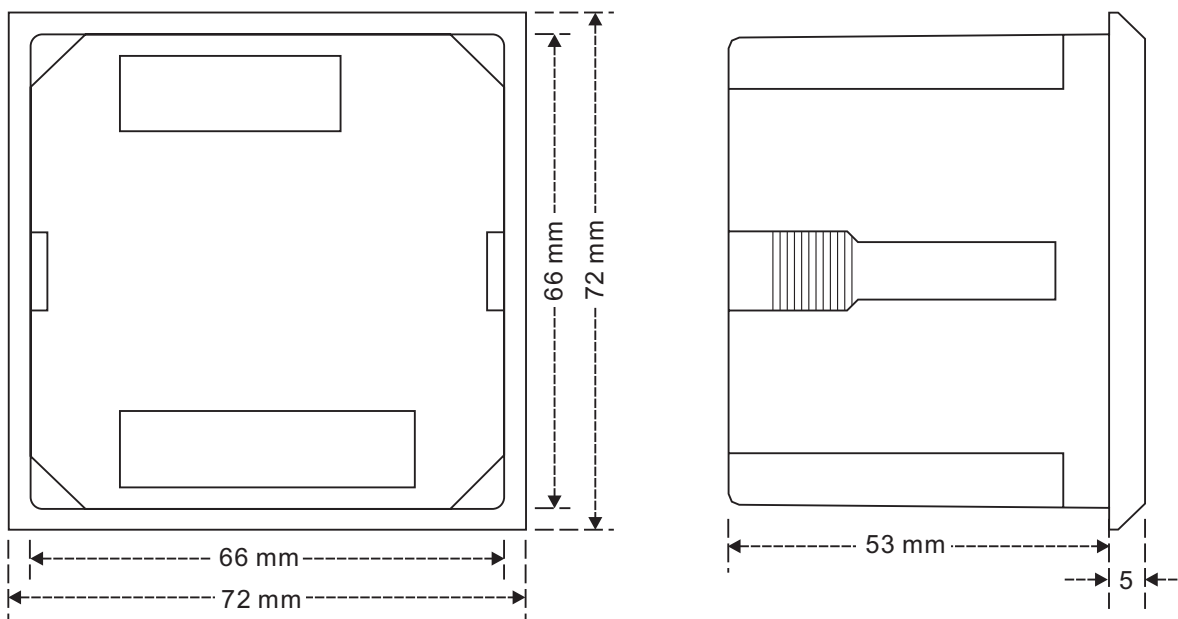

Typical connections

