



ELECTRONIC VOLTAGE REGULATOR HVR-10E

The electronic regulator **HVR-10E** is made with state-of-the-art electronic components which permit to obtain, with reduced dimensions, all needed functions to control any type of alternator.

Main features of this regulator are:

- Voltage static error within the limit of $\pm 1\%$.
- Wide stability range to guarantee the most suitable dynamic response to any situation (type of drive motor, different loads).
- Adjustable protection from over-excitation caused by anomalous loads.
- Fixed protection for low frequency operation.

Technical features:

- Supply voltage inlet: 200Vac $\pm 25\%$
- Generator output voltage setting with multi-turn trimmer (VG)
- Maximum field current: 9Adc
- Permanent field current: 7Adc
- Single-phase reference voltage inlet: 90Vac \div 440Vac
- Intervention level setting of over-excitation protection with multi-turn trimmer (OL)
- Fixed lever setting of low frequency protection

VOLTAGE REGULATION

The voltage regulator is set during testing in order to obtain a single-phase generator output voltage of 230Vac.

In case of any necessary adjustment on the voltage value, act on the VG trimmer, considering that voltage can be increased in clockwise direction.

OVERLOAD PROTECTION

The over-load protection is made to protect the alternator from over-load conditions, from high inductive load, or from low RPM operation.

The protection limits the voltage of the rotor to the set value. The protection is delayed to permit the necessary transient over-loads.

This setting value, by Linz Electric checking, may be modified through the OL trimmer as follow:

- Moving the OL trimmer in clockwise direction, the intervention rotor voltage threshold is reduced, that is means that the generator output voltage, after a programmed delay time, will reduce its value with less final load.
- By the other hand, moving the OL trimmer in counter-clockwise direction, the intervention rotor voltage threshold is increased, that is means that the generator output voltage will reduce its value with a higher final loads.

UNDER-SPEED PROTECTION

Protection from low frequency is set by Linz Electric in order to operate decreasing the generator output voltage when the frequency is below 45Hz.

ATTENTION

To avoid any damage to persons or to the equipment it is necessary that any repair of the voltage regulator is made by qualified personnel only.

APPLICATION OF HVR-10E REGULATOR ON LINZ ELECTRIC ALTERNATORS

230Vac Sensing Voltage

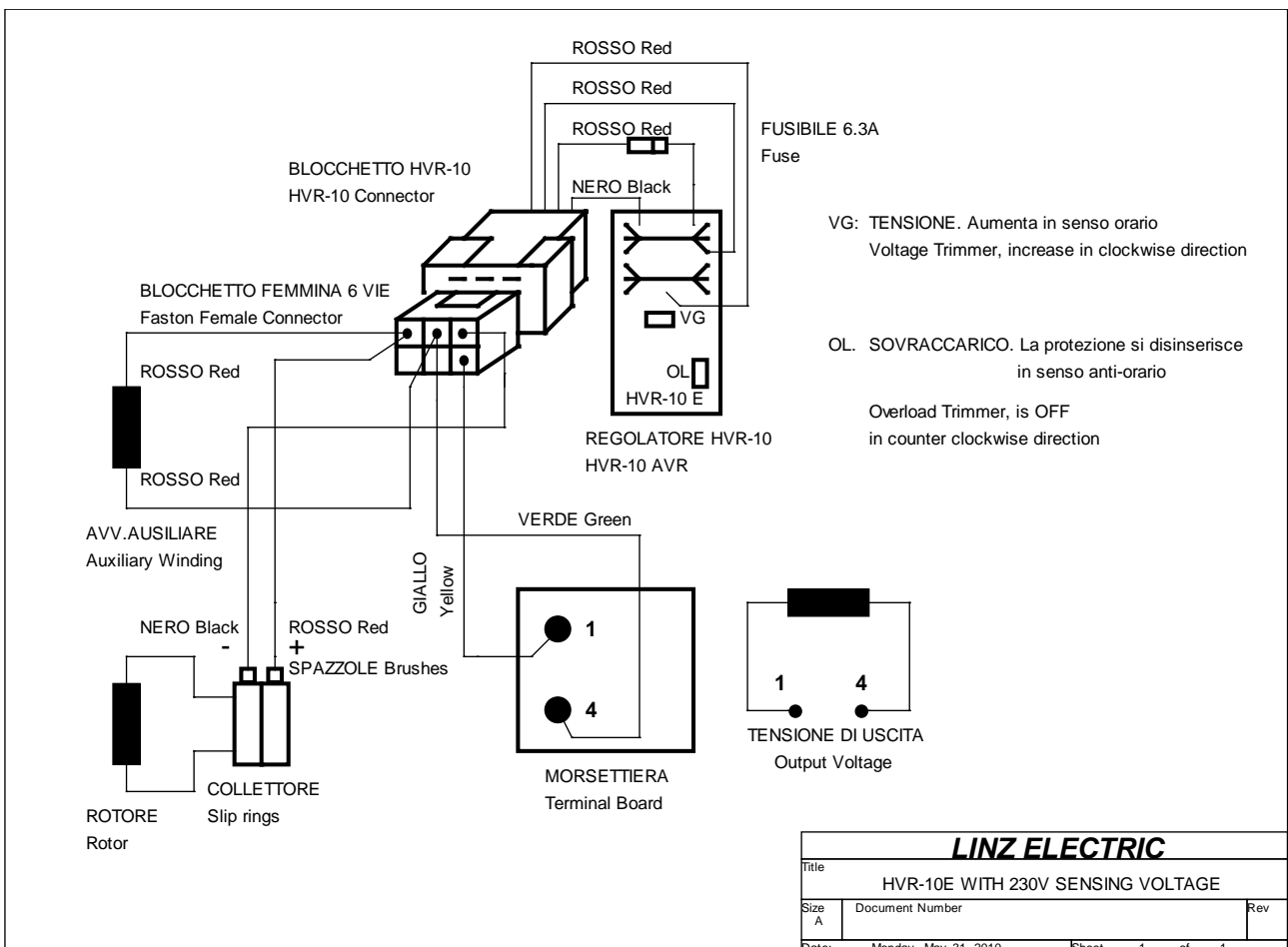

115Vac Sensing Voltage

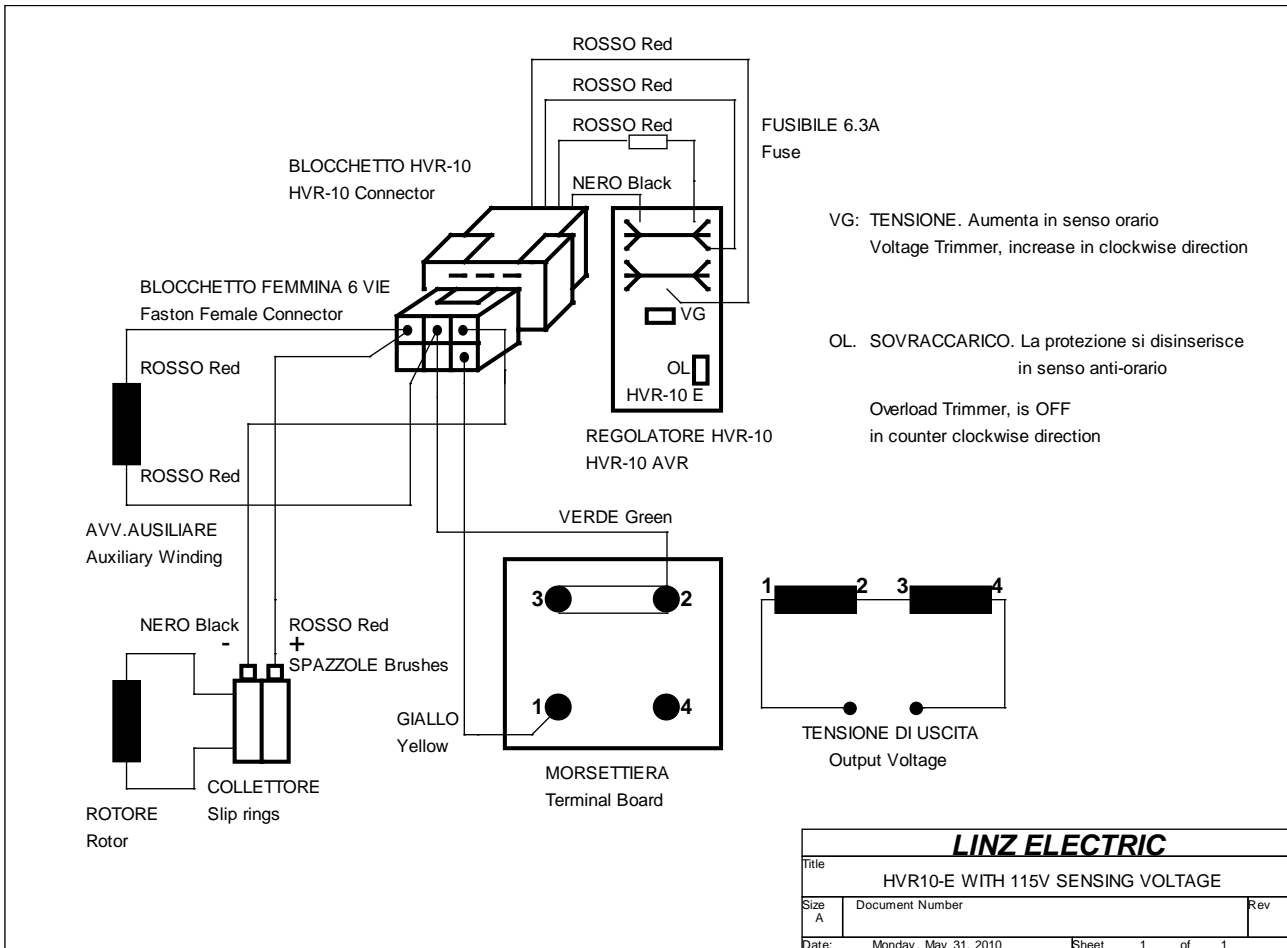

ELECTRONIC REGULATOR HVR-10

AVR Connector
Male fastons
Rear view

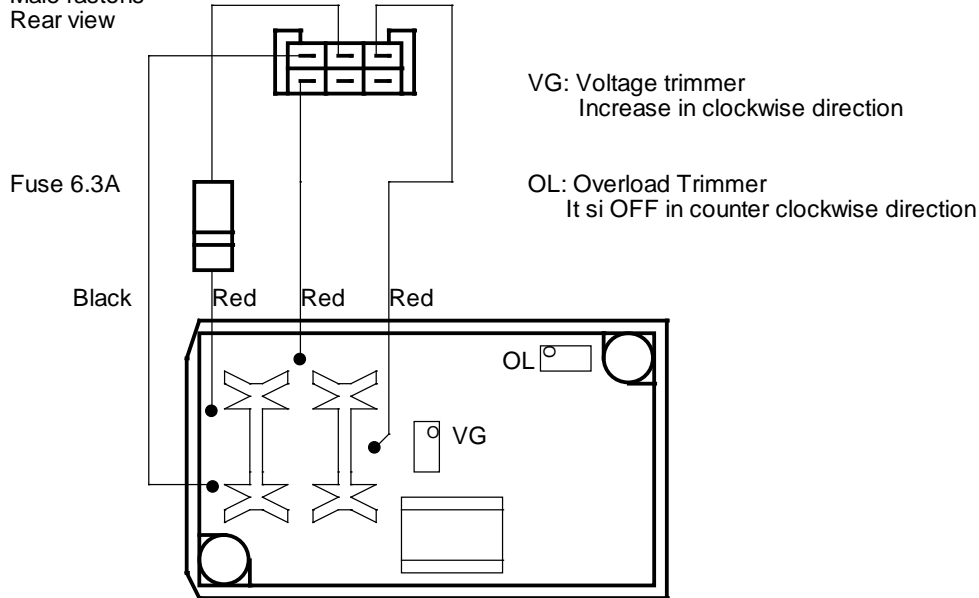

LINZ ELECTRIC

CONTROL VALUES FOR AVR TYPE HVR-10E

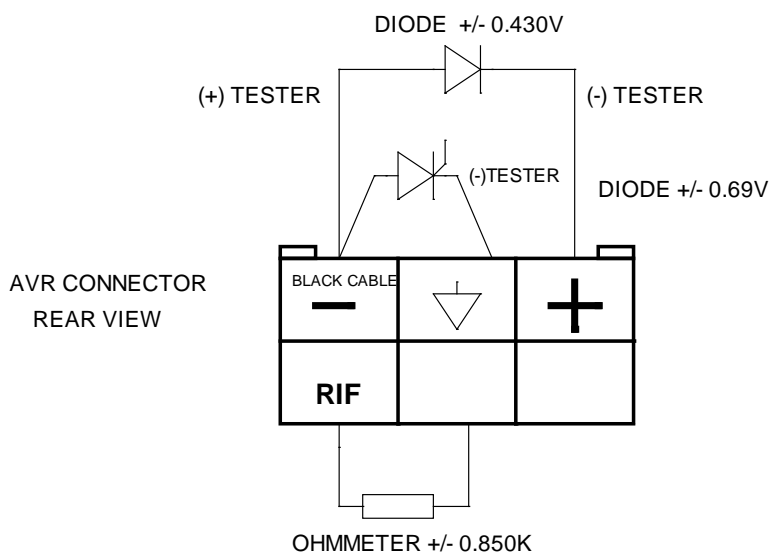

LINZ ELECTRIC

OPERATION TEST ON DISASSEMBLED REGULATOR

To verify the proper operation of the regulator proceed as follow:

- 1) Make the connection as indicated in the diagram of figure 1. To take the variac at the minimum and the switch 1 must be off.
- 2) To close the switch 1, to increase the voltage of the variac up to 75Vac, the light bulb should switch on. To increase the voltage up to 120Vac, the light bulb before switches off and immediately switches on.
- 3) To increase the voltage of the variac up to 210Vac, the light bulb should switch on and the lamp reaches the maximum brilliancy.
- 4) To wait 30 seconds approx., the light bulb should switch off, and it enters in an oscillation sequence between on condition and off condition with a period of 1 second approx.

If the conditions described above are satisfied, then the regulator works properly.

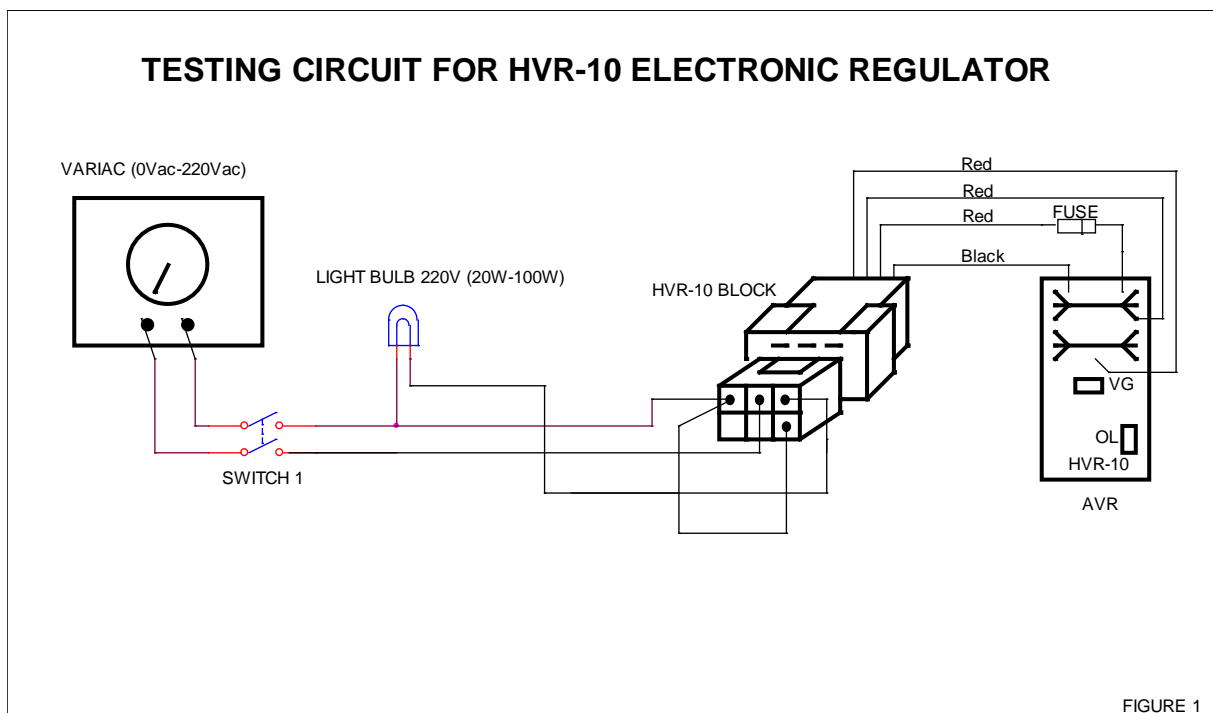

DIMENSIONS

