

# EA341

## **Generator Automatic Voltage Regulator Operation Manual**

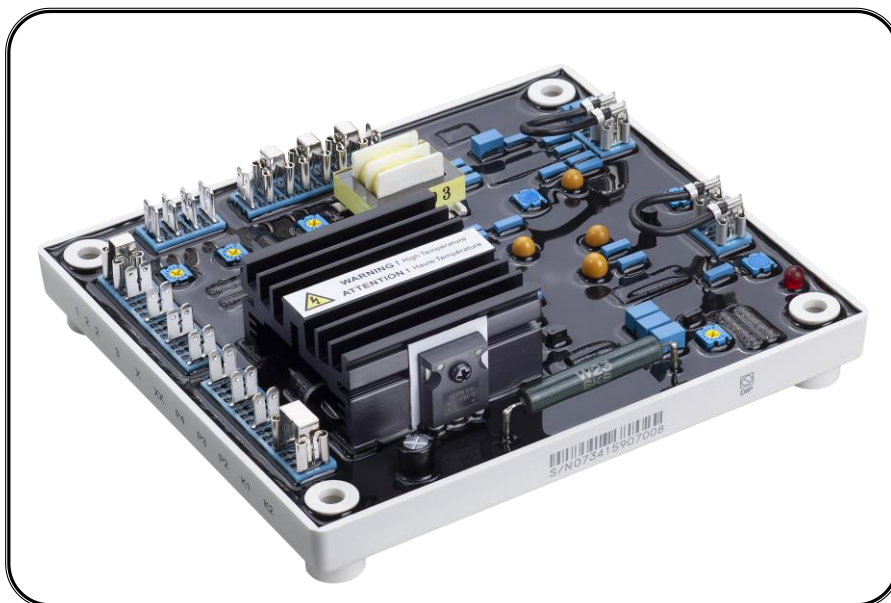

Use with PMG brushless generators  
Compatible with Newage MX341\*

\* All manufacturer names and numbers are used for reference purpose only and do not imply that any part is the product of these manufacturer.



**KUTAI ELECTRONICS INDUSTRY CO., LTD.**

TEL : +886-7-8121771

FAX : +886-7-8121775

Website : [www.kutai.com.tw](http://www.kutai.com.tw)

Headquarters : No.3, Ln. 201, Qianfu St., Qianzhen Dist., Kaohsiung City 80664, Taiwan



---

## SECTION 1 : SPECIFICATION

### Sensing Input

Voltage	190 – 264 Vac 1 phase 2 wire
Frequency	50/60 Hz, Jumper selected

### Power Input (PMG)

Voltage	170 – 220 Vac 3 phase 3 wire
Current	3A / Phase
Frequency	100 – 120 Hz, nominal

### Excitation Output

Voltage	Max. 120 Vdc @ power input 220 Vac
Current	Continuous 2.7A Intermittent 6A for 10 secs.
Resistance	Min. 15 ohm

### External Voltage Adjustment

Max. +/- 10% @ 1K ohm 1 watt potentiometer

### Voltage Regulation

Less than +/- 1% ( with 4% engine governing )

### Build Up Voltage

5 Vac residual volts at power input terminal

### Soft Start Ramp Time

2 seconds +/- 10%

### Static Power Dissipation

Max.12 watts

### Analogue Voltage Input

Input Resistance	1K ohm
Max. Input	+/- 5 Vdc
Sensitivity	1V for 5% generator volt

### Quadrature Droop Input

Burden	10 ohms
Max. input	0.33 A
Max. sensitivity	0.07 A for 5% droop (PF = 0)

### Over Voltage Detector Input

Set point	300V. Time delay 1 sec (fixed)
CB trip coil volt	10 – 30 Vdc / 0.5 Amp
CB trip coil resistance	20 – 60 ohms

### Current Limit Input

Burden	10 ohms
Sensitivity range	0.5 – 1A

### Under Frequency Protection (Factory Presets)

Set point	95% Hz
Slope	170% down to 30 Hz

### Over Excitation Protection

Set point	90 Vdc
Time delay	10 secs. (fixed)

### Voltage Thermal Drift

Less than 3% at temperature range -40 to +70 °C

### Environment

Operating Temperature	-40 to +70 °C
Storage Temperature	-40 to +85 °C
Relative Humidity	Max. 95%
Vibration	3.3 Gs @ 100 – 2K Hz

### Dimensions

150.0 (L) x 135.0 (W) x 48.0 (H) mm

### Weight

394 g +/- 2%

## SECTION 2 : GENERAL DESCRIPTION

2.1 EA341 is a two phase sensed Automatic Voltage Regulator and forms part of the excitation system for a brush-less generator. Excitation power is derived from a three-phase permanent magnet generator (PMG), to isolate the AVR control circuits from the effects of nonlinear loads and to reduce radio frequency interference on the generator terminals. Sustained generator short circuit current is another feature of the PMG system.

2.2 The AVR senses the voltage in the main generator winding and controls the power fed to the exciter stator and hence the main rotor to maintain the generator output voltage within the specified limits, compensating for load, speed, temperature and power factor of the generator.

2.3 Soft start circuitry is included to provide a smooth controlled build up of generator output voltage.

- 2.4 A frequency measuring circuit continually monitors the shaft speed of the generator and provides under-speed protection of the excitation system by reducing the generator output voltage proportionally with speed below a pre-settable threshold. A further enhancement of this feature is an adjustable VOLT per Hertz slope to improve engine recovery time on turbo charged engines. Soft start circuitry is included to provide a smooth controlled build up of generator output voltage.
- 2.5 Uncontrolled excitation is limited to a safe period by internal shutdown of the AVR output device. This condition remains latched until the generator has stopped.
- 2.6 Provision is made for the connection of a remote voltage trimmer, allowing the user fine control of the generator's output.
- 2.7 An analogue input is provided allowing connection to a controller or other external devices with compatible output.
- 2.8 The AVR has the facility for droop CT connection, to allow parallel running with other similarly equipped generators.

**NOTE :**

- (1) Derate linearly from 3.7A at 50 °C to 2.7A at 70 °C.
- (2) The stated voltage regulation may not be maintained in the presence of certain transmitted radio signals. Any change in regulation will fall within the limits in Criteria B of S.EN.61000-6-2 : 2001.
- (3) After 10 minutes.
- (4) Applies to Mod status E onwards. Generator de-rate may apply. Check with factory. Factory set, semi-sealed, jumper selectable.
- (5) Any device connected to the analogue input must be fully looting (galvanically isolated from ground), with an insulation strength of 500 Vac.
- (6) Non condensing.

**SECTION 3 : SUMMARY OF AVR CONTROLS**

CONTROL	FUNCTION	DIRECTION
VOLT	To adjust generator output voltage	Clockwise increases output voltage
STABILITY	To prevent voltage hunting	Clockwise increase the damping effect
UFRO	To set the UFRO knee point	Clockwise reduces the knee point frequency
DROOP	To set the generator droop to 5% at 0 pf	Clockwise increases the droop
TRIM	To optimize analogue input sensitivity	Clockwise increases the gain or sensitivity
EXC	To set the over excitation cut off level	Clockwise increase the cut off level
DIP	To set the frequency related voltage dip	Clockwise increases the voltage dip

## SECTION 4 : ADJUSTMENT OF AVR CONTROLS

### 4.1 Voltage Adjustment

4.1.1 The generator output voltage is set at the factory, but can be altered by careful adjustment of the VOLT control on the AVR board, or by the external hand trimmer if fitted.

Terminals J1 and J2 on the AVR will be fitted with a shorting link if no hand trimmer is required.

#### WARNING

**Do not increase the voltage above the rated generator voltage. If in doubt, refer to the rating plate mounted on the generator case.**

**Do not ground any of the hand trimmer terminals, as these could be above earth potential. Failure to observe this could cause equipment damage.**

4.1.2 If a replacement AVR has been fitted or re-setting of the VOLT adjustment is required, proceed as follows :

- (1) Before running generator, turn the VOLT control fully anti-clockwise.
- (2) Turn remote VOLT trimmer (if fitted) to midway position.
- (3) Turn STABILITY control to midway position.
- (4) Connect a suitable voltmeter (0 – 300 Vac) across line to neutral of the generator.
- (5) Start generator set, and run on no load at nominal frequency e.g. 50 – 53 Hz or 60 – 63 Hz.
- (6) If the red Light Emitting Diode (LED) is illuminated, refer to the Under Frequency Roll Off (UFRO) adjustment.
- (7) Carefully turn VOLT control clockwise until rated voltage is reached.
- (8) If instability is present at rated voltage, refer to stability adjustment, then re-adjust voltage if necessary.
- (9) Voltage adjustment is now completed.

### 4.2 Stability Adjustment

4.2.1 The AVR includes stability or damping circuit to provide good steady state and transient performance of the generator.

4.2.2 A jumper link selector is provided to optimize the response of the stability circuit to various size generators.

4.2.3 The link should be positioned as shown in the diagram according to the kw rating of the generator. The correct setting of the Stability adjustment can be found by running the generator at no load and slowly turning the

stability control anti-clockwise until the generator voltage starts to become unstable. The optimum or critically damped position is slightly clockwise from this point (i.e. where the machine VOLT are stable but close to the unstable region).

### 4.3 Under Frequency Roll Off (UFRO) Adjustment

4.3.1 The AVR incorporates an under-speed protection circuit which gives a VOLT / Hz characteristic when the generator speed falls below a presentable threshold known as the “knee” point. The red Light Emitting Diode (LED) gives indication that the UFRO circuit is operating.

4.3.2 The UFRO adjustment is preset and sealed and only requires the selection of 50 or 60 Hz and 4 pole or 6 pole, using the jumper link as shown in the diagram. For optimum setting, the LED should illuminate as the frequency falls just below nominal, i.e. 45 Hz on a 50 Hz system or 55 Hz on a 60 Hz system.

### 4.4 DROOP Adjustment

Generators intended for parallel operation are fitted with a quadrature droop C.T. which provides a power factor dependent signal for the AVR. The C.T. is connected to S1, S2 on the AVR, (see generator wiring diagram for details). The DROOP adjustment is normally preset in the works to give 5% voltage droop at full load zero power factors. Clockwise increases the amount of C.T. signal injected into the AVR and increases the droop with lagging power factor (cos Ø). With the control fully anti-clockwise there is no droop.

### 4.5 Trim Adjustment

4.5.1 An analogue input (A1, A2) is provided to connect to the controller or other devices. It is designed to accept dc signals up to +/- 5 VOLT.

4.5.2 The dc signal applied to this input adds to the AVR sensing circuit. A1 is connected to the AVR 0 VOLT. Positive on A2 increases excitation. Negative on A2 decreases excitation.

4.5.3 The TRIM control allows the user to adjust the sensitivity of the input. With TRIM fully anti-clockwise the externally applied signal has no effect. Clockwise it has maximum effect.

4.5.4 Normal setting is fully clockwise when used with a controller.

#### WARNING

**Any devices connected to this input must be fully floating and galvanically isolated from ground, with an insulation capability of 500 Vac. Failure to observe this could result in equipment damage.**

#### 4.6 Excitation (EXC) Adjustment

This adjustment is set and sealed in the works and should not be tampered with. An over excitation condition is indicated by the illumination of the red LED which also indicates under-speed running and over-volt.

The generator must be stopped to reset an over-excitation trip.

#### 4.7 DIP Adjustment

This feature is mostly used when the generator is coupled to turbo charged engines with limited block load acceptance. The feature works by increasing the V/Hz slope to give greater voltage roll off in proportion to speed.

With the DIP control fully anti-clockwise, the generator voltage will follow the normal V/Hz line as the speed falls below nominal. Turning the DIP control clockwise provides greater voltage roll off aiding engine recovery.

#### WARNING

Please make sure you have read and understand the contents of the instruction manual prior to installation. Incorrect wiring connection may result in irreversible damage to the product and other equipments.

### SECTION 5 : FITTING AND OPERATING (Refer to generator wiring diagram for connection details)

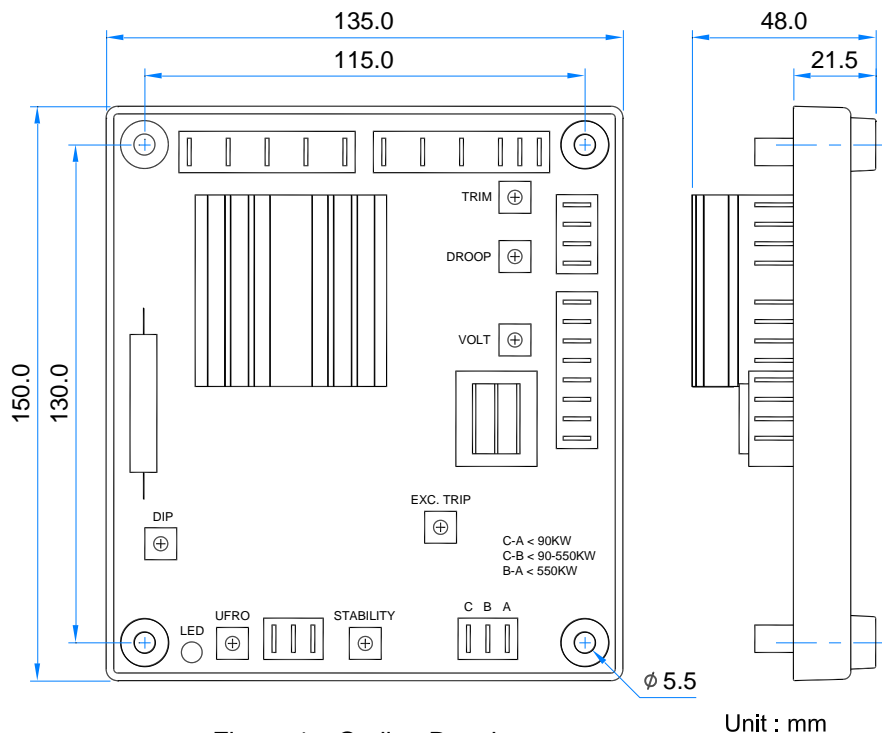

#### ATTENTION

1. AVR can be mounted directly on the engine, genset, switchgear, control panel, or any position that will not affect operation. For dimension reference, please see Figure 1.
2. All voltage readings are to be taken with an average-reading voltmeter Meggers and high-potential test equipment must not be used. Use of such equipment could damage the AVR.
3. Improper setting of under-frequency protection could cause the output voltage of the unit to drop or become unstable under with changes in load. Avoid making any changes to the U/F setting unless necessary.
4. Set the O/E potentiometer at max. position when paralleling.

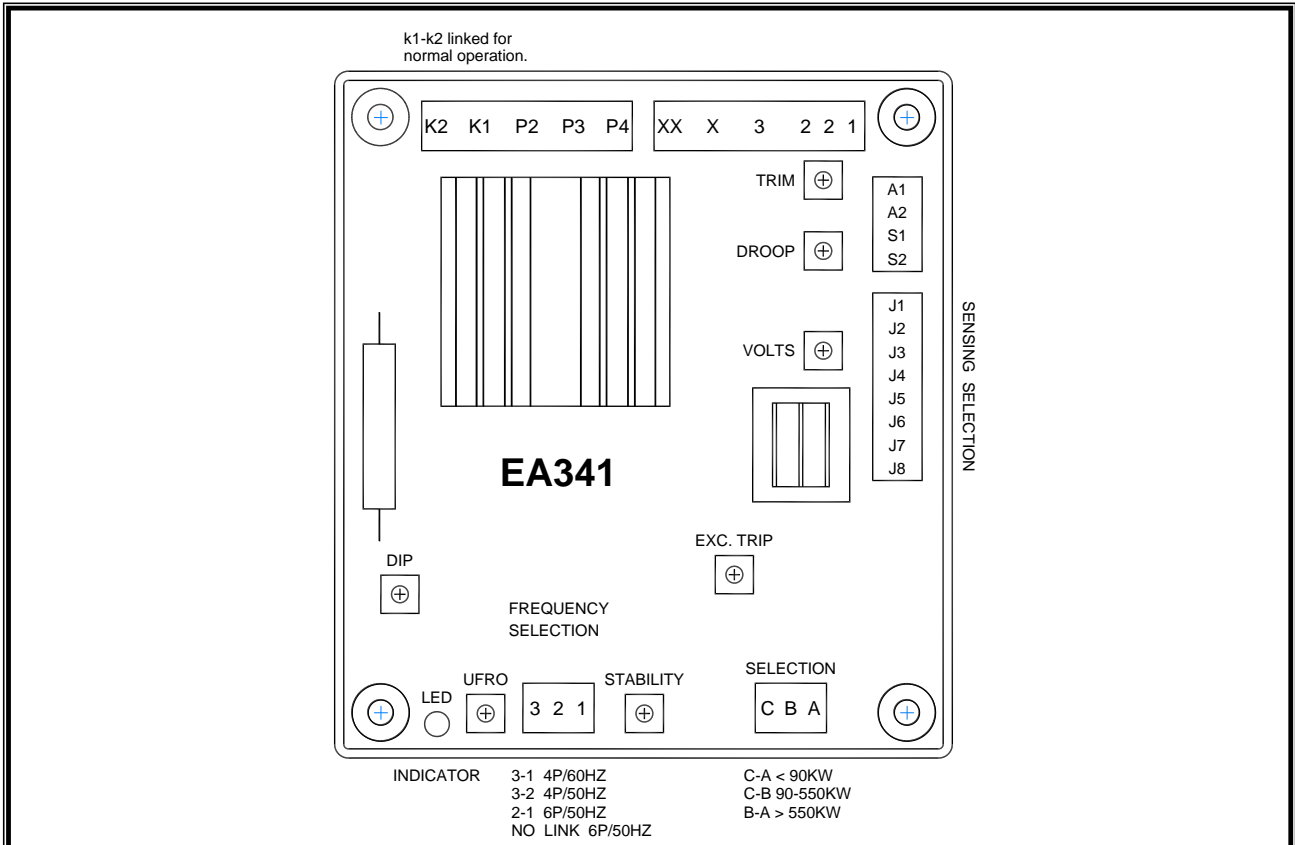

Figure 2 Disposition Drawing

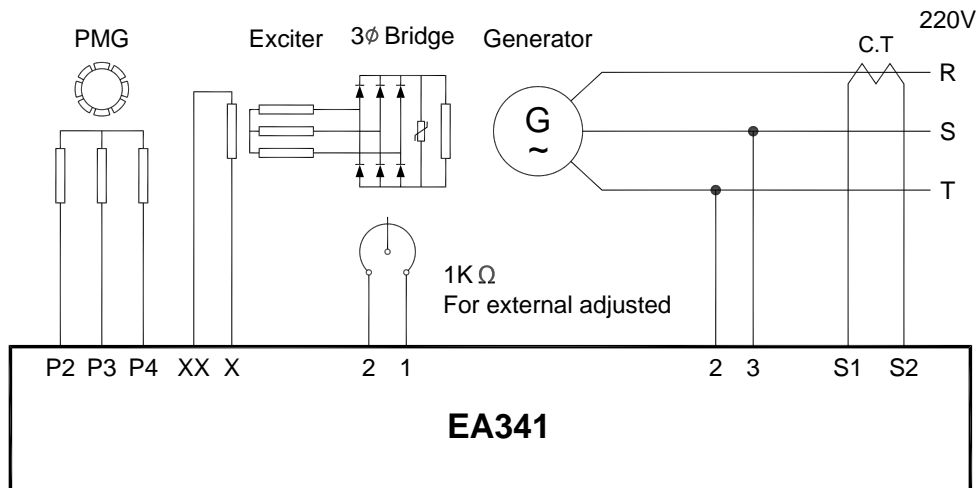

Figure 3 Wiring Drawing

Note : When the system voltage over 220 Vac, a transformer is necessary at sensing input terminal is recommend.

※ Appearance and specifications of products are subject to change for improvement without prior notice.