

ELECTRONIC VOLTAGE REGULATOR HVR-11

The electronic regulator **HVR-11** is made with state-of-the-art electronic components which permit to obtain, with reduced dimensions, all needed functions to control any type of alternator.

Main features of this regulator are:

- Voltage static error within the limit of $\pm 1\%$.
- Wide stability control regulation to guarantee the most suitable dynamic response to any situation (type of drive motor, size of alternator).
- Adjustable protection from low frequency operation.
- Adjustable protection from overexciting caused by anomalous loads.

Technical features:

- Supply voltage inlet:
 - a) 110Vac $\pm 15\%$,**
 - b) 220Vac -25%/+15%**
- Maximum field current: **10 Adc**
- Permanent field current: **7 Adc**
- Single phase reference voltage inlet: **90Vac ÷ 440Vac**
- Outlet voltage setting of the alternator with multi-round trimmer
- Stability control setting with multi-round trimmer
- Intervention level setting of low frequency protection with multi-round trimmer
- Intervention level setting of over-exciting protection with multi-round trimmer
- Remote potentiometer inlet
- Possible operation at **50Hz** or **60Hz**
- Possible operation of alternators in parallel

OPERATION AT 60 Hz

For operating at **60Hz**, connect regulator terminals **6** and **7** with a bridge.

VOLTAGE REGULATION

Voltage regulator is set during testing in order to obtain a line-to-line voltage of **400Vac/50Hz** with a reference voltage of **115Vac/50Hz** between terminals **5** and **6** of the regulator.

In case of any necessary adjustment on the voltage value, act on the VG trimmer considering that voltage can be increased with a clockwise rotation.

It is also possible to set the voltage using a remote potentiometer of **220k Ω** connecting it between terminals **6** and **8** as indicated in the electric diagram.

STABILITY CONTROL

The stability control acts on the dynamic response of the system avoiding the creation of oscillations on the outlet voltage value.

The regulator is already set by Linz Electric in order to obtain the best performance in most applications. In case of special application the regulator response can be set acting on ST trimmer; response timing can be increased with a clockwise rotation.

PROTECTION FROM LOW SPEED OPERATION

Protection from low frequency is set by Linz Electric in order to operate decreasing outlet voltage when frequency is below **47Hz**.

Acting on **Hz** trimmer with a clockwise rotation it is possible to decrease the frequency value of the operating threshold.

If the regulator is set for operation at **60Hz** (terminal 6 and 7 connected through a bridge) the intervention frequency of the protection is **57Hz**.

OVERLOAD PROTECTION

The overload protection is made to protect the alternator induction from overload conditions or from high inductive load.

The protection limits the voltage of the exciter stator to the set value; this value that limits the supply voltage of the exciter stator is set in Linz Electric and can be increased with a clockwise rotation of OL trimmer.

ATTENTION

To avoid any damage to persons or to the equipment it is necessary that any repair of the voltage regulator is made by qualified personnel only.

APPLICATION OF HVR-11 REGULATOR ON LINZ ELECTRIC PRO SERIES ALTERNATORS



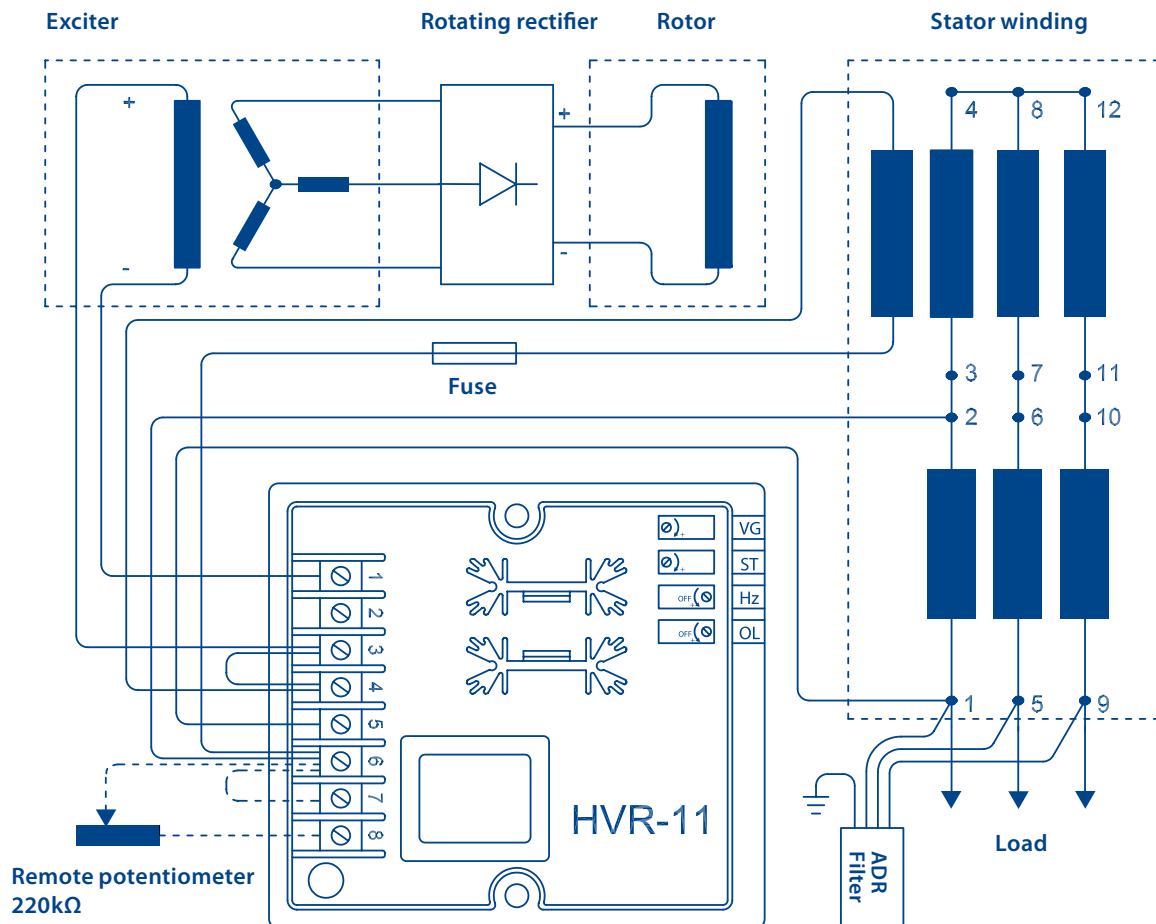

Description of Trimmers:

VG: VOLTAGE. Increases outlet voltage with a clockwise rotation.

ST: STABILITY. Increases with a clockwise rotation.

HZ: LOW FREQUENCY. Protection can be disconnected with a clockwise rotation.

OL: OVERLOAD. Protection can be disconnected with a clockwise rotation.

Description of terminals:

- 1: Negative (-) Excitation winding
- 2: 110V supply voltage inlet
- 3: Positive (+) Excitation winding
- 4: 220V supply voltage inlet
- 5: Reference voltage inlet
- 6: Return of reference voltage and supply
- 7: Bridge inlet for operating at 60Hz
- 8: Remote potentiometer inlet (+)

OPERATION TEST ON DISASSEMBLED REGULATOR

To verify the correct operation of the regulator (with standard setting), proceed as follows:

- Make the connection as indicated in the diagram of fig. 3.
- Feed the regulator with an alternating voltage of **220V 50Hz**; the light bulb should not switch on.
- Act on VG trimmer with a clockwise rotation; the light bulb will switch on progressively.
- When the maximum brilliancy is reached the light bulb will switch off and after few seconds it will switch on again.

If the above described test will succeed, the regulator works properly.

